

TRM

ON desk power module

TRM is the ultimate solution for power and data distribution in all offices and meeting rooms where reliable product and extra safety are of paramount importance.

TRM is a thermal reset power module certified with BS5733 and KM 686563, manufactured 100% in-house which allows full quality control over the components and processes.

Two UK sockets with individual On/Off switches, resettable 3A circuit breakers, a dual USB port type A+C and desk fixing c-clamp are packed into the sleek design, that allows easy access to utilities.



AVAILABLE SOCKET TYPES:



G TYPE USB CHARGER

AVAILABLE MEDIA CONNECTIONS:



DATA USB HDMI

APPROVALS & CERTIFICATES:



AVAILABLE COLOURS:



USP

- CERTIFIED WITH BS5733, KM 686563
- TWO UK SOCKETS HAVE RESETTABLE 3A THERMAL FUSES AND INDIVIDUAL ON/OFF SWITCHES
- AVAILABLE WITH 35W USB A+C CHARGER (PD & QC)
- TWO DATA BLANKS CAN INCLUDE RJ45 CAT6A, USB 3.0, USB TYPE C, OR HDMI COUPLERS
- THE MODULE IS SUPPLIED WITH A C-CLAMP DESIGNED TO FIT DESK THICKNESS FROM 15 TO 45 MM

INSTALLATION

STEP 1 - Place the module onto the edge of the desk

STEP 2 - Place the clamp onto the back of the module and tighten it using Allen Key

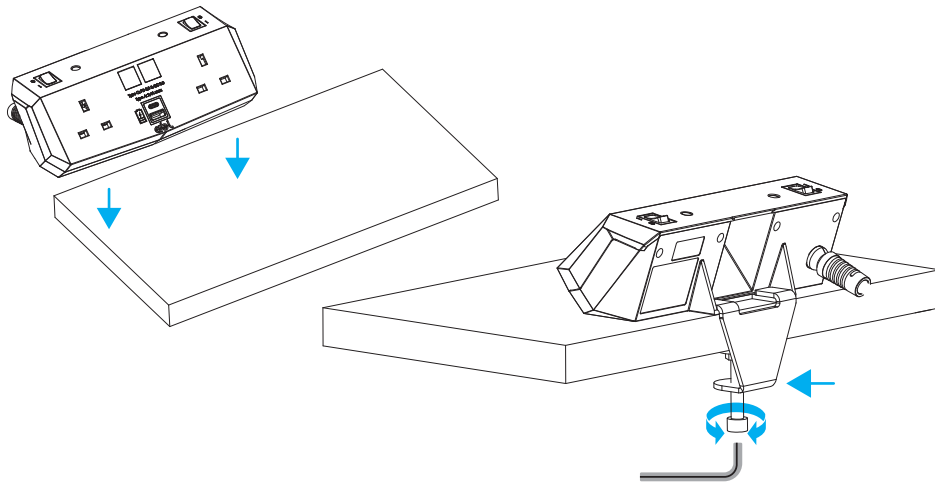

STANDARD DIMENSIONS

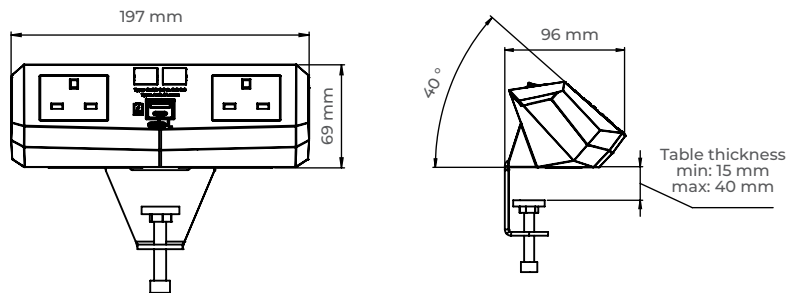

TECHNICAL

Configuration:

Power / USB A+C charger (PD & QC) combined
Power / Multimedia / USB A+C charger (PD & QC) combined
Power and Multimedia in combined units are separated internally

Additional description: TRM incorporates 'TRIP FREE' circuit breakers which comply with section 5.5.7 of BS6396:2022. A trip-free circuit breaker is a breaker that will trip (open) even if the operating mechanism ON/OFF switch is held in the ON position.

Earthing: Fully earthed

Fusing: Resettable 3A thermal fuses

Power cord: 0.5m standard lead with 3 Pole connector allows mains or connector leads to be changed to suit requirements, especially useful during moves and changes. Optionally available hardwired cable with appropriate national mains plugs.

Testing: 100% testing - continuity, polarity & earth

Testing of the USB A+C charger (PD & QC): Output voltages, current, and power in all types of charging standard.

All TRM power modules are fully manufactured in-house using ISO 9001:2015 quality-controlled practices. Power modules are tested in accredited laboratories of certification houses twice a year; while in-house quality control testing of each product is completed on every single power module before it leaves the factory.